

# Tab Position Indicator

## INSTALLATION INSTRUCTIONS READ INSTRUCTIONS COMPLETELY BEFORE BEGINNING INSTALLATION

- SYSTEM REQUIRES 12 VOLT POWER SOURCE
- IF ACTUATOR STROKE IS LESS THAN 1" OR MORE THAN 2-1/2", OR IF LESS THAN 1" OF PISTON SHAFT IS EXPOSED WHEN THE ACTUATOR IS FULLY RETRACTED, HAS EXTERNAL HYDRAULIC CONNECTION, OR THREE RINGS MOLDED ON CYLINDER BODY (SEE FIGURE 1), SPECIAL SENSOR COILS ARE REQUIRED (CONTACT BENNETT MARINE)
- MAKE ALL ELECTRICAL CONNECTIONS WITH POWER OFF
- **TEST SYSTEM BEFORE PUTTING THE BOAT BACK IN THE WATER**

### Tools required:

- |                     |                |                             |
|---------------------|----------------|-----------------------------|
| 1/2" & 7/16" Wrench | Teflon Tape    | Marine Grade Sealant        |
| 5/16" Drill Bit     | Wire Stripper  | Jewelers Small Screw Driver |
| 2" Hole Saw         | Electric Drill | Vise Grips                  |
|                     |                | Wire Cutter                 |

### Installing New Upper Hinge with Sensor

**Step 1** Inside transom, with tabs in full up position, locate trim tab hydraulic line and detach tubing from brass elbow (some fluid will drip out). While holding pipe nipples with vise grips, unscrew brass elbow. Do this procedure for port and starboard cylinders (see figure 2). If there is no pipe nipple visible inside the transom, you have a short fitting connection (see figure 3). Skip to Step 2.

**Step 2** Outside transom, snap white plastic clip on shaft protruding from bottom of cylinder. Grasp cylinder body with both hands and unscrew counterclockwise from cylinder upper hinge (a small amount of fluid will spill).

**Step 3** Insert metal rod into piston, POINTED END DOWN. Make sure that the O-ring is in place in new upper hinge with sensor coil. Screw new upper hinge onto cylinder while keeping metal rod inserted into center of sensor coil. Red cable for port side and green cable for starboard side. Tighten upper hinge hand tight. **IMPORTANT:** Use care when handling sensor coils during assembly to avoid damaging wires.

**Step 4** Remove upper hinge from transom and remove pipe nipple. If you have a short fitting use a 7/16" wrench to remove it from the upper hinge.

**Step 5** Remove plastic clip from piston and repeat steps 2 - 4 for the starboard cylinder.

**Step 6** Using template, drill 5/16" hole in transom for Trimindicator actuator cable. Screw pipe nipple into new actuator upper hinge. Tighten nipple hand tight. Then, with vise grips, tighten two full turns. . . **NO MORE.** If you have the short fitting, use a 1/2" wrench and screw it in until the fitting is snug. The shoulder of the fitting will just touch the plastic of the upper hinge.

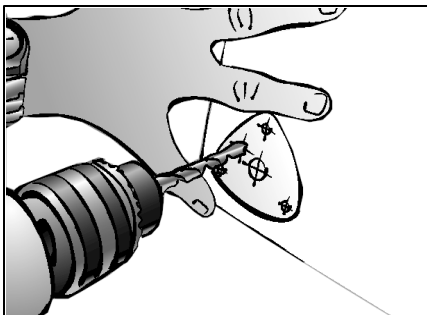

**Step 7** Cover end of pipe nipple with masking tape. Apply sealant to actuator upper hinge surface around pipe nipple, screw holes, and cable. Feed actuator cable through 5/16" hole and secure actuator upper hinge to transom with mounting screws. Grasp cylinder body with both hands and tighten (clockwise) securely. Repeat for other side. Run cables to helm.

**Step 8** Inside transom, remove masking tape from pipe nipples. Carefully wrap Teflon tape around male threads of pipe nipples. Holding pipe nipples with vise grips (to prevent them from turning) re-secure 90 degree elbows. Re-attach hydraulic tubing, tightening nut finger tight. Snug nut with 1/2" wrench. **Do NOT over-tighten.**  
**Note:** If you have the short fittings omit this step.

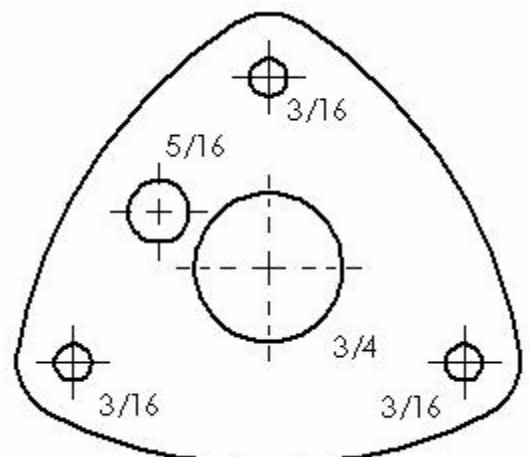
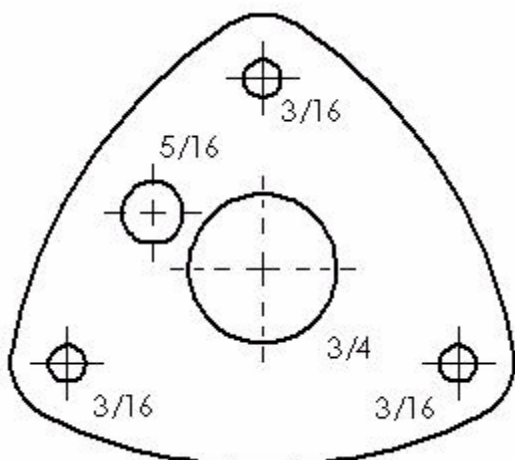
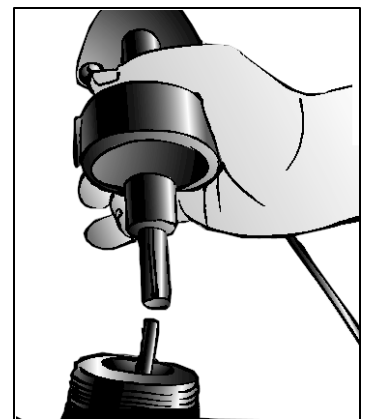
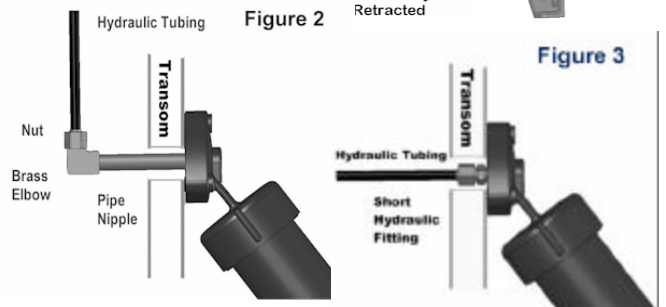
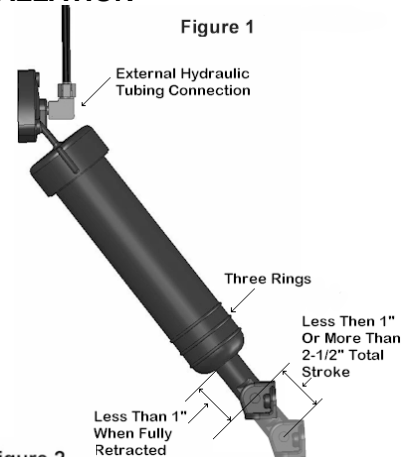

## Mounting Display

**Step 1** Choose a location for the TPI display at the helm (or place in existing 2" gauge hole if one is available). Make sure that there is no obstruction behind the dash in that location. Using the Display Retainer / Template, drill a 1/4" pilot hole. Remove the template, and snap out the pilot hole guide by twisting it back and forth.

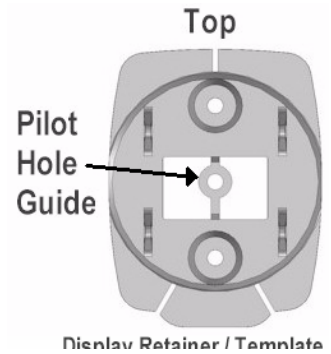
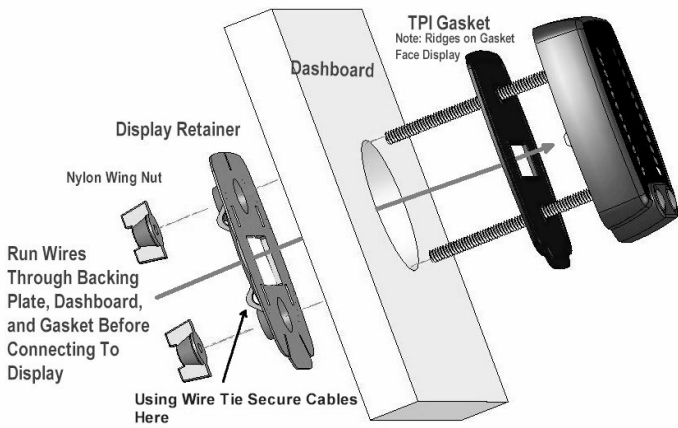

**Step 2** Using the pilot hole cut a 2" hole in the dash with the 2" hole saw.

**Step 3** Pull the Red and Green cables and Orange and Black wires through the display retainer, dashboard and TPI gasket.

**Step 4** Strip the two green wires inside the green sensor cable and insert into wire connector on the back of the TPI display in locations marked "GRN" (it does not matter which green goes in which GRN) and tighten in place

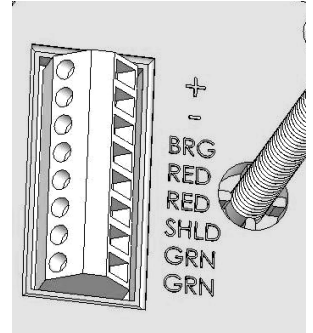

with small flat screwdriver. Repeat for red wires in red sensor cable and insert into locations marked "RED". Twist the silver shield wires together from both the red and green cables and insert into location marked "SHLD". Strip and insert the supplied black ground wire into location marked "-". Strip and insert supplied orange fused wire into location marked "+". Make sure that the fuse holder is closest to the power supply.

**Step 5** Connect black wire from display to any convenient negative ground. Connect orange "+" wire from display to 12 volt positive, such as ignition, accessories or gauges that turn on with ignition or a separate switch.

**Note:** This power lead is connected last. Use wire tie to secure wires to Display Retainer.

**Step 6** Push display into hole, seating it on the gasket. Tighten wing nuts to secure display and retainer snugly to the dashboard.

## Calibration

Make sure that both trim tabs are in the full up position. When you power up the TPI the port and starboard displays will begin to flash alternately, indicating that the system is not calibrated. Press and hold both buttons on the TPI simultaneously for about 3 seconds. Both the port and starboard lower yellow LEDs will begin to blink. Using the Trim Tab controls, run both Trim Tabs to the full down position (Bow Down on the control). **Hold the control longer than necessary to ensure that both Tabs go fully down** (this will not harm the system). A few moments after the Tabs are all the way down the upper port and starboard yellow LEDs will begin blinking. Again, using the Trim Tab Controls, run both tabs to the full up position. **Make sure the tabs come all the way up.** The upper yellow LEDs will then light up solidly indicating that the TPI is calibrated and ready to operate. If you wish to re calibrate the TPI at any time simply bring the Tabs to the full up position, hold both buttons down and repeat the calibration instructions.

## Operation

The intensity of the display may be adjusted by pressing the right button to brighten and the left button to dim the display. The TPI display may be turned off by pressing the left hand button until no display is visible.

## Diagnostic Information

**Port and Starboard display alternately flash:** TPI requires calibration. Refer to calibration information above.

**Upper Yellow LED flashes on Port or Starboard display:** Indicates the display is not receiving a sensor signal. If the port upper yellow LED flashes, the fault is in the port sensor or wires. A flashing yellow LED on the starboard display would indicate a fault on the starboard sensor or wiring. Check for a broken wire to sensor, faulty connection or corrosion at TPI display. Switching the connections on the back of the helm display will confirm the diagnostic code if the flashing LEDs switch sides. Alternatively, you may check the twisted pair of wires inside the shielded red and green cables with an Ohm meter set to the 10X scale. They should produce a reading in the 220 -260 Ohm range.



## Bennett Marine

550 Jim Moran Blvd. Deerfield Beach, FL 33442 USA

Phone 954-427-1400 Fax 954-480-2897

Web Site [www.BennettTrimTabs.com](http://www.BennettTrimTabs.com)

E-mail [Trimtabs@earthlink.com](mailto:Trimtabs@earthlink.com)